

9417 phone manual



File Name: 9417 phone manual.pdf

Size: 3588 KB

Type: PDF, ePub, eBook

Category: Book

Uploaded: 1 May 2019, 15:41 PM

Rating: 4.6/5 from 721 votes.

Status: AVAILABLE

Last checked: 1 Minutes ago!

In order to read or download 9417 phone manual ebook, you need to create a FREE account.

[**Download Now!**](#)

eBook includes PDF, ePub and Kindle version

[Register a free 1 month Trial Account.](#)

[Download as many books as you like \(Personal use\)](#)

[Cancel the membership at any time if not satisfied.](#)

[Join Over 80000 Happy Readers](#)

Book Descriptions:

We have made it easy for you to find a PDF Ebooks without any digging. And by having access to our ebooks online or by storing it on your computer, you have convenient answers with 9417 phone manual . To get started finding 9417 phone manual , you are right to find our website which has a comprehensive collection of manuals listed.

Our library is the biggest of these that have literally hundreds of thousands of different products represented.



Book Descriptions:

9417 phone manual



To add a new vehicle, select the year, make, and model at left. Our payment security system encrypts your information during transmission. We don't share your credit card details with thirdparty sellers, and we don't sell your information to others. Please try again.Please try again.In order to navigate out of this carousel please use your heading shortcut key to navigate to the next or previous heading. Please try your search again later.Click here to make a request to customer service.For more information go to www.P65Warnings.ca.gov We use only the highest materials designed specifically for your application, and apply a finish that will not only enhance the appearance of the mount, but will also help to extend the life of the mount.To calculate the overall star rating and percentage breakdown by star, we don't use a simple average. Instead, our system considers things like how recent a review is and if the reviewer bought the item on Amazon. It also analyzes reviews to verify trustworthiness. The station conferencing feature links both lines by simply pressing the conference key so you can easily hold threeway calls or bridge together the colleague and customer as you discuss urgent projects. The handsfree operation and onhook dialing lets you take part in a conference call or oneonone conversation without ever lifting the receiver. With the M9417, you dont need to dedicate a line to a fax machine or modem. The Call Director feature lets you use distinctive ringing service to economically list separate numbers for your telephone and fax or modem. The M9417 detects the special ring and automatically routes the call to the proper device. For telecommuting or workathome scenarios, the M9417 lets you use one line for business and one for personal use. When connected to an appropriate ISDN device and a standard RJ11 jack, the M9417 can be used to access ISDN services which allows you to send or receive data files wile having a conversation on just one line.<http://www.kantoromega.pl/userfiles/ennovia-edc-11r-manual.xml>

- **aastra 9417 phone manual, 9417 phone manual, 9417 phone manual pdf, 9417 phone manual download, 9417 phone manual free, 9417 phone manual online, aastra phone 9417 manual.**

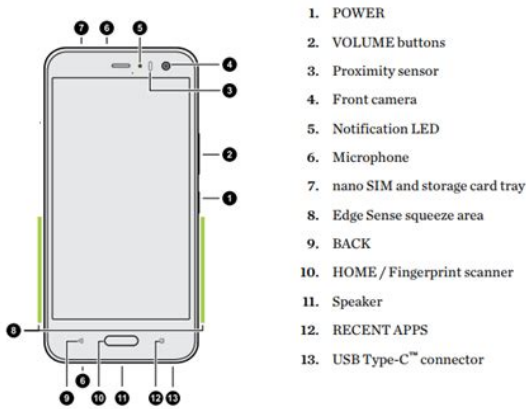

1. POWER
2. VOLUME buttons
3. Proximity sensor
4. Front camera
5. Notification LED
6. Microphone
7. nano SIM and storage card tray
8. Edge Sense squeeze area
9. BACK
10. HOME / Fingerprint scanner
11. Speaker
12. RECENT APPS
13. USB Type-C™ connector

The M9417 makes it wasy with Preferred Name Match. This model features callerIDoncallwaiting CICW version. The M9417 with CICW has a threeline, backlit display. Color options Ash, Black and Gray. Fully remanufactured with one year warranty.Be the first to write a review. If you don't retrieve the call within 15 minutes, the call is a. This automatical. You can hear your caller but your caller cannot hear you. When picking the ring tone, press A to adj. If you do not want a name, go to step. If you do not want to enter a name, go. Ensure the live dial pad option is turned off. If you do not want to enter a name, go to. Press if you want to s. To move down and up the list, press . If yo. Note If you're on a call while viewing t. This may be required if you have tried to dial. To enter a name, use the dial pad. Se. You can enter a maximum of 24 digits. Note If you requir. If the name was displayed with the number, both are now saved in. If you don't want a name, go to step 5. If the name was displayed with the number, both are now saved in. The display shows the feature name. The feature code is dialed out, which turns the f. To program the light on, press . The display shows FeatureLight ON or F. The feature and light turn on or off. When the f. The timer starts running automatically. The display shows the running time of the calls on eith. The timer stops counting. The page key has been changed to a memo. If this is the number you want to delete or change,. If the tran. Press to disable the check line cord message. Catalytic cleaning system. Electric power supply. 5 gas burners. Multi function cooking method.<http://www.nextwebdesign.co.uk/pictures/eno-emt-888-tuner-manual.xml>

Gigaset AL140/AL145

Handset



- 1 Charge status of the battery pack
- 2 Internal number of the handset
- 3 Display keys
- 4 Message key
- 5 Directory key
- 6 Control key
- 7 Talk key
- 8 End call and On/Off key
- 9 Ringer on/off (press and hold in idle status)
- 10 Keypad lock on/off (press and hold)
- 11 Recall key
- 12 Microphone
- 13 Alarm clock key

Base station



Registration/paging key (page 6)

Please note:
New messages in the calls list/answer machine (network mail-box) list (page 5) are indicated by a flashing icon in the display.

Display keys:
Pressing the keys launches whichever function that appears above them in the display.

Display icon	Function when pressed
INT	Call all registered handsets.
MENU	Open main/submenu (see Menu tree, page 11).
>	Go back one menu level.
↕	Scroll up/down or adjust volume with .
←	Move cursor to left/right with .
⌫	Backspace deletes one character at a time.
OK	Confirm menu function or save entry.

Safety precautions

- Read this user guide and the safety precautions carefully before use. Explain their contents and the potential hazards associated with using the telephone to your children.
- Only use the mains unit supplied.
- Only use the approved, rechargeable battery pack, never a conventional (non-rechargeable) battery pack, as this could result in significant health risks and personal injury. Batteries should not be disposed of in general household waste. Observe the local waste disposal regulations, which you can find out about by contacting your local authority or the dealer you purchased the product from.
- The operation of medical appliances may be affected. Be aware of the technical conditions in your particular environment, e.g. doctor's surgery.
- Do not hold the rear of the handset to your ear when it is ringing. Otherwise you risk serious and permanent damage to your hearing. The handset may cause an unpleasant humming noise in hearing aids.
- Do not install the phone in a bathroom or shower room. The handset and base station are not splashproof.
- Do not use your phone in environments with a potential explosion hazard, e.g. paint shops.

Gigaset service contact numbers:
For personal advice on our range of products and for repairs or guarantee/warranty claims call:
Service Centre UK: 08453 6708 12
(local call cost charge)
Please have your proof of purchase ready when calling.

Ventilated and multifunction cooking Wide variety of cooking methods to cook different type of food to perfection Closed door grilling Keeps cooking smell inside the oven and ensures a safe cooking environment Catalytic Special selfcleaning enamel attracts fat and degrades fats and remnants of food left over after cooking. Made in Italy Manufactured in Italy to grant the best quality and crafted design TECHNICAL DETAILS Width of the product 900 Width of the packed product 960 Depth of the product 600 Depth of the packed product 685 Height of the product 850 Height of the packed product 850 Net weight kg 62 Gross weight kg 69.7 Current A 10 Length of electrical supply cord cm 120 Dimension of 1st heating element 130 Dimension of 2nd heating element 70 Dimension of 3rd heating element 70 Dimension of 4th heating element 50 EAN code 8003437219856 Construction Type Freestanding MAIN FEATURES Adjustable feet Yes all Integrated Cleaning system Catalytic all sides PERFORMANCES Power of 1st heating element 3700 Power of 2nd heating element 1800 Power of 3rd heating element 1800 Power of 4th heating element 1000 User Manuals Whirlpools user manuals are included with your product on delivery. You can also download your user manual here. Instruction for Use English Download Product Information English Download Energy label English Download Warranty We know that enjoying complete peace of mind is essential when purchasing a new appliance. For any purchase, you receive a standard 1 full years' Parts and Labour warranty. For more details and warranty extension in your country kindly check Whirlpool local distributor policy. Press to return to the previous menu; or press and hold to return to idle mode, without making changes. q Press and hold to set and turn on the quiet mode, or turn it off.

Delete digits or characters while using the dialing keys. 4JMFOD FUIFSJOH FSUFNQPS BSJMZXIJ MFUIF IBOETFUJ TSJOHJO H q Make or answer a call using the handset speakerphone. During a call, press to switch between the speakerphone and the handset earpiece. q While you have set the dial mode to pulse and on a call, press to switch to tone dialing temporarily. q Press to add a space when entering names. q Press repeatedly to add or remove 1 in front of the caller ID log entry before dialing or saving it to the phonebook. Press and hold to set or dial your voicemail number. q Make or

answer a call. Answer an incoming call when you hear a call waiting alert. q Press repeatedly to review the redial list. Press and hold to insert a dialing pause while entering a number. q Review the phonebook when the phone is not in use. Increase the listening volume during a call. Scroll up while in a menu, phonebook, caller ID log, or redial list. Move the cursor to the right when entering numbers or names. Review the caller ID log when the phone is not in use. Decrease the listening volume during a call. Scroll down while in a menu, phonebook, caller ID log, or redial list. Review the phonebook when the phone is not in use. Scroll up while in a menu, or in the phonebook, caller ID log or redial list. Move the cursor to the right when entering numbers or names. Increase the listening volume during a call or message playback. Show a menu. While in a menu, press to select an item, or save an entry or setting. Review the caller ID log when the telephone is not in use. Scroll down while in a menu, or in the phonebook, caller ID log or redial list. Move the cursor to the left when entering numbers or names. Decrease the listening volume during a call or message playback. Press to return to the previous menu or idle mode without making changes. Press and hold to erase the missed call indicator when the phone is not in use. On when a handset is being registered.

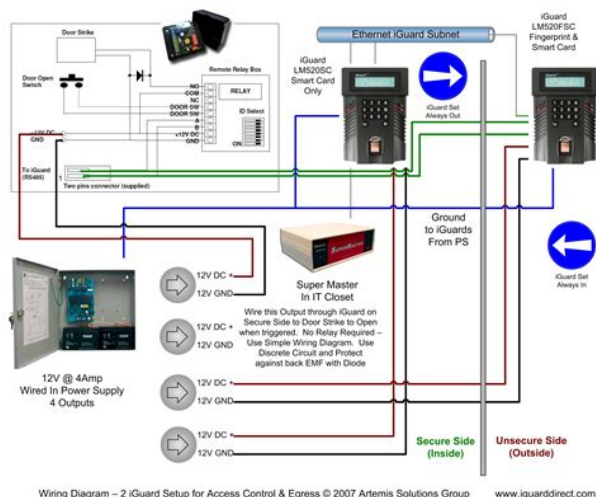

<https://skazkina.com/ru/bose-wave-ipod-dock-manual>

Flashes when there is an incoming call. Flashes when handsets are being deregistered. Flashes when there are new messages or memos in the answering system. While reviewing the redial list, phonebook or caller ID log, press to delete an individual entry. While entering names or numbers, press to delete a character or digit. Press once to repeat the playing message. Press twice to play the previous message. Silence the base ringer temporarily while the phone is ringing. Press to page all handsets when the phone is not in use. VOL Adjust the listening volume. Adjust the telephone base ringer volume. Review the redial list. Press repeatedly to view the last 10 numbers dialed. There are new voicemail received from your telephone service provider. PDF Version 1.5. Linearized Yes. Author whtang. Instance ID uuid7edc93633a8245d7947ecbe298995383. Document ID adobedocidindd97b9640f626011e5b3ca914e08d15793. Rendition Class proofpdf. Derived From Instance ID 97b9640e626011e5b3ca914e08d15793. Derived From Document ID adobedocidindd3bf8e2c746ec11e589249e0d161e3664. Creator Tool Adobe InDesign CS2 4.0. Thumbnail Format JPEG. Thumbnail Width 256. Thumbnail Height 256. Thumbnail Image Binary data 11582 bytes, use b option to extract. Title manual 1.pdf. Creator whtang. Producer Acrobat Distiller 10.0.0 Windows. Trapped False. Page Count 2. Get Details. Our factories use only top quality components, and manufacture to strict ISO, QS, and TS Standards, and testing. We use only the highest grade rubber and steel designed specifically for your application, and apply a finish that will not only enhance the appearance of the mount, but will also help to extend the life of the mount. All trademarks are property of their respective owners. This website is a free service and the links

on this page are for Aastra is a registered trademark of Aastra Telecom, Ltd.; Avaya is a. The first 4 characters of the case number is the movement number.

<http://alliaksesuar.com/images/canon-pixma-ip8500-manual-download.pdf>

VOKIA N71 Mobile Phone Component

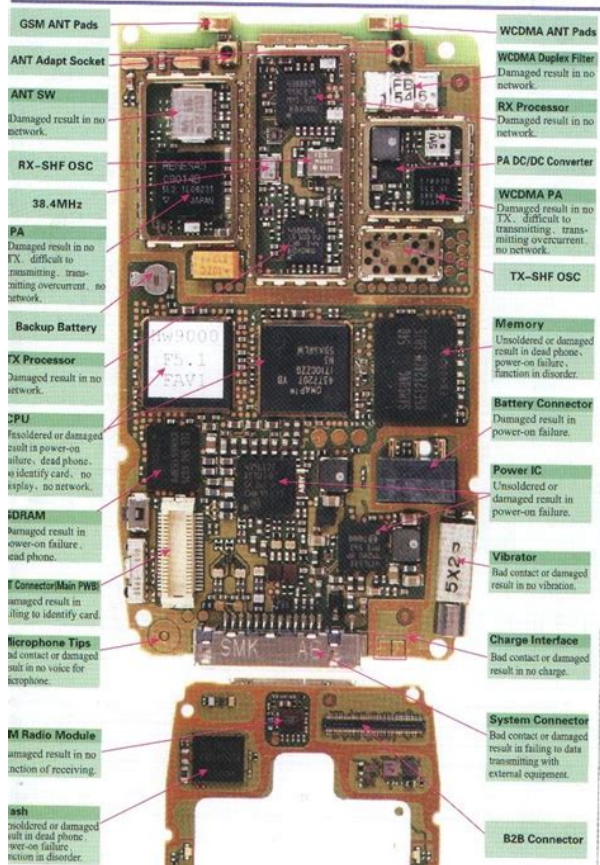

By continuing to browse our website you accept the use of such cookies. For our privacy policy. If you want NextDay, we can save the other items for later. Order by, and we can deliver your NextDay items by. You won't get NextDay delivery on this order because your cart contains items that aren't "NextDay eligible". In your cart, save the other items for later in order to get NextDay delivery. Oops! There was a problem with saving your items for later. You can go to cart and save for later there. Get more info No machine included. REPRINT of the manual listed in title. This is NOT an original as originals are out of print, but we use the best scans available. Plastic Comb Bound with clear plastic on front and back covers to help protect manual. All manuals are in public domain or printed with permission. About This Item We aim to show you accurate product information. Manufacturers, See our disclaimer This is NOT a sewing machine, serger, or embroidery machine. This is an OWNERS INSTRUCTION MANUAL ONLY. No machine included. Ask a question Ask a question If you would like to share feedback with us about pricing, delivery or other customer service issues, please contact customer service directly. So if you find a current lower price from an online retailer on an identical, instock product, tell us and we'll match it. See more details at Online Price Match. All Rights Reserved. To ensure we are able to help you as best we can, please include your reference number Feedback Thank you for signing up. You will receive an email shortly at Here at Walmart.com, we are committed to protecting your privacy. Your email address will never be sold or distributed to a third party for any reason. If you need immediate assistance, please contact Customer Care. Thank you Your feedback helps us make Walmart shopping better for millions of customers. OK Thank you! Your feedback helps us make Walmart shopping better for millions of

customers. Sorry.

<https://www.gamastech.com/images/canon-pixma-ip8500-printer-manual.pdf>



We're having technical issues, but we'll be back in a flash. Done. Post your question here in this forum. We're committed to dealing with such abuse according to the laws in your country of residence. When you submit a report, we'll investigate it and take the appropriate action. We'll get back to you only if we require additional details or have more information to share. Note that email addresses and full names are not considered private information. Please mention this; Therefore, avoid filling in personal details. Please enter your email address. Page 24 2198.1 rus 03032003 1011 Pagina 22 22. This document for download All trademarks and brands are the property of their respective owners. The field is considered in its broadest perspective, including theory, practice and research applications related to all ages, special populations, settings, and interdisciplinary collaborations in both the public and private sectors. Through critical study, expositions, and review of practice, Archives of Psychiatric Nursing is a medium for clinical scholarship to provide theoretical linkages among diverse areas of practice. Benefits to authors We also provide many author benefits, such as free PDFs, a liberal copyright policy, special discounts on Elsevier publications and much more. Please click here for more information on our author services. Please see our Guide for Authors for information on article submission. If you require any further information or help, please visit our Support Center. You may choose to submit your manuscript as a single Word or PDF file to be used in the refereeing process. Only when your paper is at the revision stage, will you be requested to put your paper in to a correct format for acceptance and provide the items required for the publication of your article. To find out more, please visit the Preparation section below.

Aims and Scope Archives of Psychiatric Nursing disseminates original, peer-reviewed research that is of interest to psychiatric and mental health care nurses. Manuscripts should be voluntary contributions submitted for the exclusive use of the Archives of Psychiatric Nursing. The purpose of

the Archives of Psychiatric Nursing is to disseminate knowledge to guide educators, scientists, and practitioners of psychiatric and mental health nursing. Archives of Psychiatric Nursing considers psychiatric and mental health nursing in its broadest perspective, including theory, practice, education, research, and policy applications related to all ages, special populations, settings, mental health disciplines, and both the public and private sectors. Archives of Psychiatric Nursing is a medium for clinicianscholars to provide theoretical linkages among diverse areas of practice. Manuscripts are sought that will inform current practice and shape public policy for the delivery of psychiatric and mental health nursing services. Style The 6th edition of the American Psychological Association Publication Manual 2010 provides the format for text and references. Titles should be short. Abbreviations should be spelled out for the first time they are used. Symbols, other than standard statistical symbols, should be identified the first time they are used. The manuscript must be accompanied by an abstract of no more than 100 words; 35 key words are to be included on the abstract page. Tables and figures should be typed or drawn on one page and relative placement should be noted in the text. Procedure Direct editorial questions to Joyce J. Fitzpatrick, PhD, RN, FAAN, Elizabeth Brooks Ford Professor of Nursing, Frances Payne Bolton School of Nursing, Case Western Reserve University, 10900 Euclid Avenue, Cleveland, OH 44106. Accepted manuscripts become the property of the Archives of Psychiatric Nursing.

<https://www.a2zmedical.com.au/wp-content/plugins/formcraft/file-upload/server/content/files/162801508303f3---Browning-automatic-shotgun-manual.pdf>

The editorial staff reserves the right to edit all manuscripts for its style and space requirements and for the purpose of clarity. The Editor of the Archives of Psychiatric Nursing will determine in which volume and issue accepted manuscripts will appear. Authors are responsible for obtaining permission for reproducing copyrighted materials and for sending a copy of that permission to the publisher before publication. Submission checklist You can use this list to carry out a final check of your submission before you send it to the journal for review. Please check the relevant section in this Guide for Authors for more details. Ethics in publishing Please see our information pages on Ethics in publishing and Ethical guidelines for journal publication. Studies in humans and animals If the work involves the use of human subjects, the author should ensure that the work described has been carried out in accordance with The Code of Ethics of the World Medical Association Declaration of Helsinki for experiments involving humans. The manuscript should be in line with the Recommendations for the Conduct, Reporting, Editing and Publication of Scholarly Work in Medical Journals and aim for the inclusion of representative human populations sex, age and ethnicity as per those recommendations. The terms sex and gender should be used correctly. Authors should include a statement in the manuscript that informed consent was obtained for experimentation with human subjects. The privacy rights of human subjects must always be observed. The sex of animals must be indicated, and where appropriate, the influence or association of sex on the results of the study. Declaration of interest All authors must disclose any financial and personal relationships with other people or organizations that could inappropriately influence bias their work. Authors must disclose any interests in two places 1.

A summary declaration of interest statement in the title page file if doubleblind or the manuscript file if singleblind. If there are no interests to declare then please state this Declarations of interest none. This summary statement will be ultimately published if the article is accepted. 2. Detailed disclosures as part of a separate Declaration of Interest form, which forms part of the journals official records. It is important for potential interests to be declared in both places and that the information matches. More information. Submission declaration and verification Submission of an article implies that the work described has not been published previously except in the form of an abstract, a published lecture or academic thesis, see Multiple, redundant or concurrent publication for more information, that it is not under consideration for publication elsewhere, that its publication

is approved by all authors and tacitly or explicitly by the responsible authorities where the work was carried out, and that, if accepted, it will not be published elsewhere in the same form, in English or in any other language, including electronically without the written consent of the copyright holder. To verify originality, your article may be checked by the originality detection service Crossref Similarity Check. Use of inclusive language Inclusive language acknowledges diversity, conveys respect to all people, is sensitive to differences, and promotes equal opportunities. Content should make no assumptions about the beliefs or commitments of any reader; contain nothing which might imply that one individual is superior to another on the grounds of age, gender, race, ethnicity, culture, sexual orientation, disability or health condition; and use inclusive language throughout. These guidelines are meant as a point of reference to help identify appropriate language but are by no means exhaustive or definitive.

Authorship All authors should have made substantial contributions to all of the following 1 the conception and design of the study, or acquisition of data, or analysis and interpretation of data, 2 drafting the article or revising it critically for important intellectual content, 3 final approval of the version to be submitted. Changes to authorship Authors are expected to consider carefully the list and order of authors before submitting their manuscript and provide the definitive list of authors at the time of the original submission. Any addition, deletion or rearrangement of author names in the authorship list should be made only before the manuscript has been accepted and only if approved by the journal Editor. To request such a change, the Editor must receive the following from the corresponding author a the reason for the change in author list and b written confirmation email, letter from all authors that they agree with the addition, removal or rearrangement. In the case of addition or removal of authors, this includes confirmation from the author being added or removed. Only in exceptional circumstances will the Editor consider the addition, deletion or rearrangement of authors after the manuscript has been accepted. While the Editor considers the request, publication of the manuscript will be suspended. If the manuscript has already been published in an online issue, any requests approved by the Editor will result in a corrigendum. Article transfer service This journal is part of our Article Transfer Service. This means that if the Editor feels your article is more suitable in one of our other participating journals, then you may be asked to consider transferring the article to one of those. If you agree, your article will be transferred automatically on your behalf with no need to reformat. Please note that your article will be reviewed again by the new journal. More information.

Copyright Upon acceptance of an article, authors will be asked to complete a Journal Publishing Agreement see more information on this. An email will be sent to the corresponding author confirming receipt of the manuscript together with a Journal Publishing Agreement form or a link to the online version of this agreement. Subscribers may reproduce tables of contents or prepare lists of articles including abstracts for internal circulation within their institutions. Permission of the Publisher is required for resale or distribution outside the institution and for all other derivative works, including compilations and translations. If excerpts from other copyrighted works are included, the authors must obtain written permission from the copyright owners and credit the sources in the article. Elsevier has preprinted forms for use by authors in these cases. For gold open access articles Upon acceptance of an article, authors will be asked to complete an Exclusive License Agreement more information . Permitted third party reuse of gold open access articles is determined by the authors choice of user license. Author rights As an author you or your employer or institution have certain rights to reuse your work. More information. Elsevier supports responsible sharing Find out how you can share your research published in Elsevier journals. If the funding sources had no such involvement then this should be stated. Open access Please visit our Open Access page for more information. Elsevier Researcher Academy Researcher Academy is a free elearning platform designed to support early and midcareer researchers throughout their research journey. Feel free to use these free resources to improve your submission and navigate the

publication process with ease. Language usage and editing services Please write your text in good English American or British usage is accepted, but not a mixture of these.

Authors who feel their English language manuscript may require editing to eliminate possible grammatical or spelling errors and to conform to correct scientific English may wish to use the English Language Editing service available from Elsevier's Author Services. Informed consent and patient details Studies on patients or volunteers require ethics committee approval and informed consent, which should be documented in the paper. Appropriate consents, permissions and releases must be obtained where an author wishes to include case details or other personal information or images of patients and any other individuals in an Elsevier publication. Written consents must be retained by the author but copies should not be provided to the journal. Only if specifically requested by the journal in exceptional circumstances for example if a legal issue arises the author must provide copies of the consents or evidence that such consents have been obtained. For more information, please review the Elsevier Policy on the Use of Images or Personal Information of Patients or other Individuals. Unless you have written permission from the patient or, where applicable, the next of kin, the personal details of any patient included in any part of the article and in any supplementary materials including all illustrations and videos must be removed before submission. Submission Our online submission system guides you stepwise through the process of entering your article details and uploading your files. The system converts your article files to a single PDF file used in the peerreview process. Editable files e.g., Word, LaTeX are required to typeset your article for final publication. All correspondence, including notification of the Editors decision and requests for revision, is sent by email. Submit your article Please submit your article via. NEW SUBMISSIONS Submission to this journal proceeds totally online and you will be guided stepwise through the creation and uploading of your files.

The system automatically converts your files to a single PDF file, which is used in the peerreview process. As part of the Your Paper Your Way service, you may choose to submit your manuscript as a single file to be used in the refereeing process. This can be a PDF file or a Word document, in any format or layout that can be used by referees to evaluate your manuscript. It should contain high enough quality figures for refereeing. If you prefer to do so, you may still provide all or some of the source files at the initial submission. Please note that individual figure files larger than 10 MB must be uploaded separately. References There are no strict requirements on reference formatting at submission. References can be in any style or format as long as the style is consistent. Use of DOI is highly encouraged. The reference style used by the journal will be applied to the accepted article by Elsevier at the proof stage. Note that missing data will be highlighted at proof stage for the author to correct. Formatting requirements There are no strict formatting requirements but all manuscripts must contain the essential elements needed to convey your manuscript, for example Abstract, Keywords, Introduction, Materials and Methods, Results, Conclusions, Artwork and Tables with Captions. Divide the article into clearly defined sections. Figures and tables embedded in text Please ensure the figures and the tables included in the single file are placed next to the relevant text in the manuscript, rather than at the bottom or the top of the file. The corresponding caption should be placed directly below the figure or table. Permissions The author is responsible for obtaining written permission to use any copyrighted materials, including illustrations, photographs, tables, and any content taken from Web sites. Documentation of permission to reprint copyrighted materials should be submitted electronically when the article is submitted.

Additional information on securing permissions can be found at. Peer review This journal operates a double blind review process. All contributions will be initially assessed by the editor for suitability for the journal. Papers deemed suitable are then typically sent to a minimum of two independent expert reviewers to assess the scientific quality of the paper. The Editor is responsible for the final decision regarding acceptance or rejection of articles. The Editors decision is final. More information

on types of peer review. Doubleblind review This journal uses doubleblind review, which means the identities of the authors are concealed from the reviewers, and vice versa. More information is available on our website. To facilitate this, please include the following separately Title page with author details This should include the title, authors names, affiliations, acknowledgements and any Declaration of Interest statement, and a complete address for the corresponding author including an email address. Blinded manuscript no author details The main body of the paper including the references, figures, tables and any acknowledgements should not include any identifying information, such as the authors names or affiliations. REVISED SUBMISSIONS Use of word processing software Regardless of the file format of the original submission, at revision you must provide us with an editable file of the entire article. Keep the layout of the text as simple as possible. Most formatting codes will be removed and replaced on processing the article. The electronic text should be prepared in a way very similar to that of conventional manuscripts see also the Guide to Publishing with Elsevier . See also the section on Electronic artwork. To avoid unnecessary errors you are strongly advised to use the spellcheck and grammarcheck functions of your word processor. Article structure Subdivision unnumbered sections Divide your article into clearly defined sections.

<http://fscl.ru/content/bose-wave-ipod-dock-manual>