



File Name: canon 1d mk4 user manual.pdf

Size: 1604 KB

Type: PDF, ePub, eBook

Category: Book

Uploaded: 16 May 2019, 18:38 PM

Rating: 4.6/5 from 670 votes.

Status: AVAILABLE

Last checked: 11 Minutes ago!

In order to read or download canon 1d mk4 user manual ebook, you need to create a FREE account.

[**Download Now!**](#)

eBook includes PDF, ePub and Kindle version

[Register a free 1 month Trial Account.](#)

[Download as many books as you like \(Personal use\)](#)

[Cancel the membership at any time if not satisfied.](#)

[Join Over 80000 Happy Readers](#)

Book Descriptions:

We have made it easy for you to find a PDF Ebooks without any digging. And by having access to our ebooks online or by storing it on your computer, you have convenient answers with canon 1d mk4 user manual . To get started finding canon 1d mk4 user manual , you are right to find our website which has a comprehensive collection of manuals listed.

Our library is the biggest of these that have literally hundreds of thousands of different products represented.



Book Descriptions:

canon 1d mk4 user manual



Upon completion of the download, the PDF file opens automatically. You may download and use the Content solely for your personal, noncommercial use and at your own risks. Canon shall not be held liable for any damages whatsoever in connection with the Content, including, without limitation, indirect, consequential, exemplary or incidental damages. You shall also not and shall not let others reproduce, modify, reformat or create derivative works from the Content, in whole or in part. This page requires Javascript. Modify your browsers settings to allow Javascript to execute. See your browsers documentation for specific instructions. To install your download click on the name of the downloaded file. Recommended Software File Name Date File Size Optional Software File Name Date File Size Recommended Manuals File Name Date File Size Optional Manuals File Name Date File Size The sole warranty, if any, with the respect to such nonCanon brand items is given by the manufacturer or producer thereof. This limited warranty covers all defects encountered in normal use of the Product, and does not apply in the following cases If the problem cannot be corrected over the telephone, you will be asked to follow the applicable procedures for MAILIN SERVICE. Note that a dated proof of purchase is required at the time of service. MAILIN SERVICE is a program under which your Product is repaired by a Canon U.S.A. or a Canon Canada authorized service center for the Product. Authorized service center information can be obtained by visiting www.canontechsupport.com US customers only or by contacting the Canon U.S.A., Customer Care Center or Canon Canada Customer Information Centre at 1800OKCANON 18006522666. You will be given the name, address and phone number of an authorized service center. <http://www.karkarlandas.lt/fckeditor/editfiles/dlse-enforcement-policies-and-interpretations-manual.xml>

- **canon 1d mark iv user manual, canon 1d mark iv instruction manual, canon eos 1d mark iv user manual pdf, canon eos 1d mark iv instruction manual, canon 1d mk4 user manual, canon 1d mk4 user manual pdf, canon 1d mk4 user manual download, canon 1d mk4 user manual free, canon 1d mk4 user manual instructions.**



It is your responsibility to properly package and send the defective Product, together with a copy of your dated proof of purchase, a complete explanation of the problem and a return address to the authorized service center at your expense. Do not include any other items with the defective Product. The Product covered by this limited warranty and proven to be defective upon inspection will be repaired and returned to you without charge by the authorized service center. Any Product received by the authorized service center that is not covered by the limited warranty will be returned unrepaired, or at the discretion of the authorized service provider, you may receive a written estimate of repair at such cost as the service center may establish from time to time. If 3 is set and an MRAW image is taken, the fourth character will be M. The above three settings also apply to the file name for movies. Switching to another AF point possible. 2. Face detection Live mode Face detection, Contrast AF. When multiple faces are detected, face selection is possible with the multicontroller. Magnified view not possible. 3. Quick mode 45point, phasedifference AF Same as viewfinder shooting, Oneshot AF. Manual AF point selection enabled. Scroll down to easily select items to add to your shopping cart for a faster, easier checkout. Visit the Canon Online Store Adapter EcC, EdC Designed for use in warm and humid or cold weather when fogging is most likely to occur, and attaches easily to reduce condensation and help you maintain a clear view of your subject. Exact battery info can be viewed on the camera's menu. Holds 12 Cameras bodies, 34 lenses and accessories. Inside measurements W x H x D 10 x 14.75 x 5 inches. Rugged nylon, waterrepellent, urethane coated for extra durability. Wellarranged divider system for secure storage and easy access. Lightweight construction, padded shoulder straps and back for comfort. Front webbing ideal for storing a light jacket. Tripod carrying straps. <http://fenixfalt.com/userfiles/dlse-manual-opinion-letters.xml>



Color Black with Olive. It is designed to hold two 35mm SLR bodies, 5 8 lenses, plus film and accessories. It features a 3way pan head for precise control and smooth movement. The 3section tubular leg construction allows for exceptional stability indoors or out. The lens fits into the eyepiece holder of you EOS camera. Please see the Compatibility tab for a list of compatible EOS cameras. The lens fits into the eyepiece holder of you EOS camera. Please see the Compatibility tab for a list of compatible EOS cameras. The lens fits into the eyepiece holder of you EOS camera. Please see the Compatibility tab for a list of compatible EOS cameras. The lens fits into the eyepiece holder of you EOS camera. Please see the Compatibility tab for a list of compatible EOS cameras. The lens fits into the eyepiece holder of you EOS camera. Please see the Compatibility tab for a list of compatible EOS cameras. The lens fits into the eyepiece holder of you EOS camera. Please see the Compatibility tab for a list of compatible EOS cameras. This is because the microlens on the screens matte is optimally shaped to increase defocusing near the point of focus. It is brighter, less grainy and better balanced. The cameras AF points remain fully visible. It is for general photography. It is for closeup and microphotography, and for determining magnification ratios and composition. It is for general photography. Standard for EOS 3. It is an overall bright laser matte and incorporates center spot metering. Standard for EOS 1N RS. The strap attaches to the eyelets at the sides of the camera. Features adjustable tripod straps, and high strength buckles for the main compartment. The Canon logo is embroidered on the top flap. The Remote Switch works just like a shutter button, enabling halfway or complete pressing.

This remote switch has a selftimer, interval timer, long exposure timer and exposurecount setting feature. The timer can be set from 1 second to 99 hours. A new dial enables you to easily enter the numeric settings with a single thumb. The cable connects to your camera and to the USB port on your PC or MAC Computer. Comes standard with the EOS 1Ds Mark III, 1D Mark IV, 1D Mark III, 5D Mark II, 7D, 60D, 50D, 40D, Rebel T2i, Rebel T1i, Rebel XSi and Rebel XS. Please see Compatibility tab for compatible models. The cable connects to your camera and to the USB port on your PC or MAC Computer. Please see Compatibility tab for compatible models. Comes standard with the EOS 1D Mark IV, 7D, 60D, Rebel T3i and Rebel T2i. Please see Compatibility tab for compatible models. Supports Canons new Camera Linking feature. Supports USB Host connection to GPS unit or external HD. There are two versions of the EDSDK compatible with Windows or Macintosh. EOS M and EOS R Full Frame mirrorless ranges deliver the power of DSLR in the body of a compact camera. Register your product and opt in for exclusive offers and discounts. We have 10 Canon EOS 1D Mark IV manuals available for free PDF download Instruction Manual, Brochure, Quick Start Manual, Pocket Manual You Shall Not Install or Use the. Please check the box to consent to

receiving electronic messages from Canon Canada Inc., which include relevant information about products, services and promotions. You may withdraw your consent at any time by selecting NO. Any pending input will be lost. Doubleclick the icon of the saved PDF file to open. Upon completion of the download, the PDF file opens automatically. Was this answer helpful. Please include additional comments below. Please try again. If you require assistance, please visit our. Canon EOS1D Mark IV DSLR equipped with a highresolution 16.

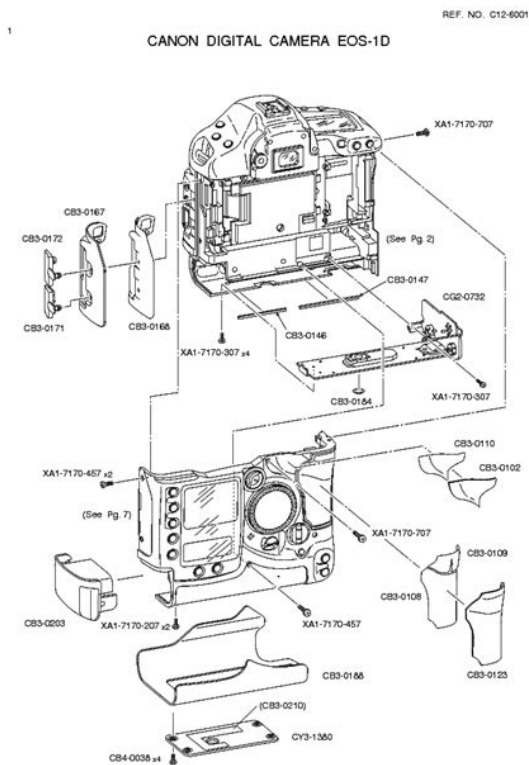

<https://congviendis.vn/vi/4-speed-manual-transmission-dodge>

1 MP APSH sized CMOS sensor, dual powerful DIGIC 4 Image Processors, a spectacular ISO range of 100 to 12800 expandable to 102400 in H3 mode with an advanced noise reduction system captures stunningly sharp, lownoise images even in lowlight conditions. The 45point AF system including 39 crosstype, highprecision AF points for exacting and fast focusing no matter the subject. The AI Servo II AF focus tracking features improved algorithms that help improve stability, reliability and focus no matter the situation. The EOS1D Mark IV delivers professional photographers with the performance to meet any challenge. Thats a responsibility we take seriously, one that deserves the best effort were capable of. The current exposure mode is displayed on the toppanel status display and the rearpanel LCD, but not in the optical viewfinder displays. The exposure mode can be changed by pressing this button and rotating the Main or Quick Control dials. Available exposure modes are P Programmed Auto, Av Aperture Priority, M Manual, Tv Shutter Priority, and Bulb. Like all Canon professional cameras, the 1D Mark IV doesnt offer any scene modes. This could come into play if you were shooting in shutterpriority mode to achieve a motionblur effect, but the light suddenly got brighter, pushing the required aperture value beyond what the lens could provide. In this situation, the camera would automatically boost the shutter speed the minimum amount needed to achieve a good exposure. Alternatively, the safety shift function can work by adjusting the ISO sensitivity, in which case it is available in P, Tv, or Av modes. AE Allows you to set the lens aperture with available apertures depending on the lens in use, while

the camera selects the most appropriate shutter speed. You have control over all other exposure variables, including exposure compensation. Since both variables are controlled manually, exposure compensation isn't available.

<http://esteticistapilarruiz.com/images/brother-pe300s-manual.pdf>



The metered exposure level is indicated in the viewfinder and if enabled on the rear panel LCD display, providing a guide to the appropriate exposure. Again, you have control over all other exposure variables, including exposure compensation. This is useful for long exposures such as night scenes, fireworks, and astrophotography. The top Status display reports the elapsed time, in hours, minutes and seconds, as the exposure progresses. The minutes and seconds values appear to the left of the aperture value, while the hours appear to the right of the aperture value when applicable. The use of an RS80N3 Remote Switch or TC80N3 Timer Remote Controller is recommended. Once either mode is activated, the Set button serves to enter or exit Live View or Movie mode, at which time the camera's mirror and shutter open, and a live preview image is shown on the LCD. There are a few important differences, though. The only metering mode available is Evaluative, and in burst shooting, the 1D Mark IV will not adjust the exposure between subsequent frames. These include Live mode contrast detection from the autofocus sensor, Face Detect Live mode similar, but the camera detects faces in the scene, and selects one for focusing, and finally Quick mode briefly interrupts live view to focus using the dedicated AF sensor. If desired, an exposure simulation function sets the preview to reflect the current exposure variables, although in extremely bright or dark conditions, this may not be possible. Unlike most other moviecapable SLR cameras on the market, the Canon 1D Mark IV can perform single autofocus operations during movie operation, although even with USM lenses, some degree of focusing noise is picked up on the audio track. Like most digital SLR video modes, continuous autofocus isn't available in Movie mode. Another feature of the 1D Mark IV is movie mode that's rather uncommon is that it allows fully manual control over aperture, shutter speed, and optionally ISO sensitivity.

<http://esxpublishers.com/images/brother-pe700ii-manual.pdf>



The 1D Mark IV's internal microphone is monaural, but the camera also includes an external microphone jack compatible with stereo microphones. Movie recording capacity varies based on the size of memory card you're using, but is in all cases limited to a maximum of 29 minutes and 59 seconds. That's thanks to European tax regulations, but as it turns out, the 4GB limit on video file sizes will in practice restrict you to shorter movie clips anyway. AF modes are identical to the Live View mode, and the grid function is also available, but the exposure simulation function is replaced by an option to disable audio in Movie mode, and the image magnification function is only available before recording starts. Playback mode lets you view, protect, or erase images and movies, or copy them between flash cards in each of the camera's dual slots. Still images can be magnified, rotated, or set up for printing on DPOF-compatible devices. You can also view an index display of all images and movies, with either four or nine thumbnails per page. A slide show function is available, and allows the user to select whether the 1D Mark IV should display just still images, just movies, or both together. It also allows the slide show to be restricted to stills and movies from a specific date or folder. The Info button toggles between displaying the image or movie alone, with a basic information display, with a detailed information display including luminance histogram which can optionally be changed through the Playback menu to display separate RGB histograms instead, and finally a partial information display plus both RGB and luminance histograms. Menu Options Screen 1 Five different custom white balance settings can be recorded. The edit caption option allows a 20 character name to be assigned to each custom white balance preset. Regardless of the menu language in use, only English upper and lowercase letters, numbers, and a limited selection of punctuation characters are available.

Filters are None, Yellow, Orange, Red, or Green. Toning effects are None, Sepia, Blue, Purple, or Green. Menu Options Screen 2 Default is 8 for all image sizes. The EOS1D Mark IV has two reduced resolution RAW options, MRAW and SRAW. You can select any size and quality Raw and JPEG simultaneously, or select only to record in one file format. If both formats are set to disabled, the setting will automatically revert to saving Large JPEGs only. If Record Function in Setup Screen 1 is set to Rec.Dust shadows can then be automatically removed from the images when they're processed through Canon's software. Menu Options Screen 1 Protected images can only be deleted by reformatting the memory card. A third press will return the image to its original rotation. Movies

cannot be rotated, and still images will only be shown as rotated in camera Canons software, Protected images are not deleted. Print order information isnt transferred to the copied image. Menu Options Screen 2 Users can choose to play all folders, one folder, or just photos taken on a particular date. The Menu button stops playback. Menu Options Screen 1 Auto switch media is the same as standard, but will switch to the second card slot once the first is full. For both the last two options, identical file names are used for each image on both cards with the exception of extension, as applicable. Also, if either card fills up, you cant continue shooting on the remaining card using these two options. Movies cannot be recorded to two cards simultaneously, and will hence write to whichever card slot has been selected for playback. If Record Func. is set to Rec. Separately or Rec. to Multiple, then this option changes to affect Playback only. Menu Options Screen 2 Up to 10x magnification is available to assist in critical manual focusing before movie capture starts, but is not available during movie recording. The grids disappear as soon as movie recording starts. If successful, an Exp.

<http://lawcab.ru/wp-content/plugins/formcraft/file-upload/server/content/files/16270c02e233cc---boto-neira-manual.pdf>

SIM icon is shown on the LCD display. If unsuccessful, the icon blinks. Selects the video resolution and frame rate. Available frame rates depend on Video System setting in Setup Menu screen 2. 30 and 60fps are available only for NTSC mode, 25 and 50 fps are only for PAL mode. 24 fps is available for both modes. Menu Options Screen 3 Settings files can be given an eight character name, and are saved with the extension.CSD. Function Menu Options These can subsequently be recalled temporarily by holding in the AE Lock button briefly. Optionally, this can also trigger an AF cycle. Not available in bulb mode. May lead to slight increase in noise levels. May cause an increase in noise levels, and should be disabled if a dark image look is desired. Doesnt apply to bulb mode, which always disables the displays. Doesnt apply to contrast detection focusing in Live View mode. In All 45 Points mode, an 18point area is used centered on the manually selected point, and can track the subject as it moves around the frame. Ninepoint options offer center point plus eight points either surrounding the spot metering circle, or at the outer periphery of the AF area. 11 point mode is similar to outer 9 points, but adds a point on either side of the spot metering circle.The AF point is registered by selecting the point, then pressing the ISO button while holding down the AF point selection button.The last two options allow you to simultaneously transpose the functions of the exposure compensation button with either the AF point selection or ISO buttons. All can be set in 1 second intervals from 0 to 59 seconds, or one minute intervals from 1 to 60 minutes. During Live View and Movie shooting. Framing lines are shown on the LCD monitor. Menu Options Menu Canon. Please improve this by adding secondary or tertiary sources. January 2011 Learn how and when to remove this template message By using this site, you agree to the Terms of Use and Privacy Policy.

It retains the twogrip form factor of the original, 4MP EOS1D launched in September 2001 itself building on the integrated grip of the filmera EOS1N RS, also the first to offer 10fps shooting, albeit without AF between shots. And its this consistency of design, which extends to the AF pattern and much of the control layout, that helps to explain the name the Mark IV really is the current point in an evolutionary process, rather than a wholly separate model. Whereas, in the past, Canons flagship models have been a fairly safe bet, autofocus problems with the 1D Mark III have cast a shadow over the range. Those problems, which appear to have come from a combination of manufacturing error, increased complexity of AF customization and the AF sensor occasionally being overwhelmed in bright conditions, have become notorious. Since then, however, a combination of engineering revisions and user education have meant that many shooters have been able to use the camera without any problems Canon admits there have been issues, but the woes that were so widely reported early in the cameras life span are unlikely still to be affecting nearly as many users as its internet reputation might suggest. Although the 45 AF points are arranged in a layout that dates

back to 1998s EOS 3, the 1D Mark IV uses a totally new AF sensor with 39 crosstype points that are sensitive both in the vertical and horizontal axis. The AF point selection method has also been revised, both for manual selection and for automated selection with subject tracking via the new AIServo II system. This may not seem like many in the era of 25MP fullframe DSLRs and 14MP compacts, but its a lot when you consider the Mark IV still has the ability to shoot at 10 frames per second.

If you consider that this is almost the same resolution as offered by the last generation of Canons studiotargeted camera, the 1Ds Mark II, but with the ability to shoot twice as fast, then you start to appreciate what this camera is promising to do. Sadly the release of the EOS1D Mark III coincided with one of the busiest periods in dpreviews history including an office and studio move, staff recruitment and training and more consumer level DSLR launches than ever before, meaning that, although much work was done and thousands of sample shots were taken, our review of that camera was never completed. EOS1D Mark III feature and specification differences I was browsing Craigslist and saw a great deal on one of these cameras and wanted to see what DPR said about it. What really blows me away is how incisive and intelligent this review is. It is my vote that Richard Butler cease whatever it is he does now and resume writing reviews like this one. I also switched off between covering news and high school sports. So I have some LIMITED photojournalism experience with a Nikon D1 kit. I have since changed careers, but I still think I know at least a thing or two about what pros look for in a camera like this. And I still do a lot of amateur shooting as an enthusiast even though no one is paying me. In photojournalism, especially sports, especially in lowlight situations, you can never have too much ISO flexibility because you have to keep the shutter speeds so fast. You have to capture and freeze the action as its happening. Thats why the 1.3x crop is so baffling on a camera like this when Nikons flagship has full frame. Sure, 10 fps is great, but so is a usable photo of night HS football at ISO 12800. This is probably OK if not doing sports though; compactness could be an advantage for news. These days hes fond of the Canon EOS 1DX when hes out shooting water sports, ski jumps, cycling and the occasional offroad rally. Both updates are available for immediate download.

Read our full review to see why its got the best autofocus system weve ever seen. 708 Olympus OMD EM10 Mark IV initial review first impressions Aug 4, 2020 at 0600 The Olympus OMD EM10 IV is the companys entrylevel DSLRshaped mirrorless camera. While it has a higher resolution sensor and new processor, its biggest focus is on selfies. 2257 Sony a7S III initial review Jul 28, 2020 at 1400 The Sony a7S III is a 12MP fullframe camera primarily designed with video in mind. We take a look beyond the specs to see what it offers to filmmakers. 1606 Olympus OMD EM1 Mark III review review Jul 27, 2020 at 1450 The Olympus OMD EM1 Mark III is our favorite Micro Four Thirds camera for stills shooters to date. In this roundup we take a look at four travel tripods and pick our favorite. In our latest buying guide weve selected some cameras that might be a bit older but still offer a lot of bang for the buck. These midrange cameras should have capable autofocus systems, lots of direct controls and the latest sensors offering great image quality. Best cameras for sports and action Aug 11, 2020 at 0146 Whats the best camera for shooting sports and action. Fast continuous shooting, reliable autofocus and great battery life are just three of the most important factors. In this buying guide weve roundedup several great cameras for shooting sports and action, and recommended the best. Best enthusiast long zoom cameras Jul 16, 2020 at 2329 Longzoom compacts fill the gap between pocketable cameras and interchangeable lens models with expensive lenses, offering a great combination of lens reach and portability. Read on to learn about our favorite enthusiast long zoom cameras. Aug 19, 2020 5 lens news Oppo shows off its nextgeneration optical zoom camera module with 85135mm equivalent focal length The camera module, which has an 85mm through 135mm fullframeequivalent focal length range, also features an updated version of Oppos Hybrid Zoom technology that results in clearer images.

Aug 19, 2020 35 mobile Panasonic will announce, via livestream, its new Lumix S5 fullframe camera on September 2 Panasonic's new Lumix S5 fullframe camera system will be revealed via a livestreamed event on September 2, 2020. Aug 19, 2020 138 camera news Sony a9 II review The Sony a9 II didn't make a huge splash in the industry when it launched, but it certainly left an impression on us. Read our full review to see why it's got the best autofocus system we've ever seen. Aug 19, 2020 431 review ZTE to launch the first smartphone with underdisplay front camera on September 1st After we've seen prototype designs from Xiaomi and Oppo, rival ZTE is now the first manufacturer to launch a device featuring the new technology. Aug 18, 2020 77 mobile Report Air Force One nearly collided with a drone, investigation launched On Sunday night, witnesses on board Air Force One spotted a drone. The White House has launched an investigation into the near collision. Aug 18, 2020 320 Tamron 24mm F2.8 M12 sample gallery Introduced alongside 20mm and 35mm siblings, the Tamron 24mm F2.8 is a lightweight and lowcost option for fullframe Sony shooters. Aug 18, 2020 48 sample gallery New York City map makes it easy to find historical images of NYC from 1939 to 1941 The map uses the NYC Municipal Archives digitized collection of historical photos captured by the NYC Tax Department. Aug 17, 2020 42 Case dismissed against George Steinmetz, whose drone was confiscated for documenting mass burials Back in April, awardwinning photographer George Steinmetz had his drone confiscated for documenting mass burials on Hart Island. Charges have since been dropped and his drone has been returned. Aug 17, 2020 58 Video How to thoroughly clean and disinfect your camera Olympus Europe has partnered with photographer Fernando Marmolejo to create a video guide on how to keep your cameras and lenses clean and disinfected.

Aug 17, 2020 222 video Adobe opens up free registration for its alldigital Adobe MAX 2020 conference More than 250 speakers will take part in the event, including Annie Leibovitz, Tyler the Creator, Ava DuVernay, Keanu Reeves and others. The conference is scheduled for October 19-21. Aug 17, 2020 25 Exploring the Alvord Desert with Andy Maser and the DJI Mavic Air 2 Join filmmaker Andy Maser and drone pilot Alex Emberlin as they use the new DJI Mavic Air 2 to explore the beautiful Alvord Desert in Oregon. Aug 17, 2020 Sponsored Nikon AFS Nikkor 120300mm F2.8E FL ED SR VR sample gallery The Nikkor 120300mm F2.8 has all the trappings of a prograde lens it's unapologetically heavy, offers weather sealing and sports an alphabet soup of special lens elements and coatings in its name. Take a look at our samples. There's still time to enter before the finalists are selected though if you have a funny photo of your pets. We've been shooting with a final copy to see how it looks for everything from portraits to street photography and landscapes. Aug 16, 2020 208 sample gallery DPReview TV Sigma 85mm F1.4 DG DN Art review Sigma has been cranking out some fantastic lenses lately, and the new 85mm F1.4 DG DN Art joins the club. Find out why we like this fast, compact lens. Includes updated sample gallery. Aug 15, 2020 141 video Hasselblad adds iPhone connectivity to its Phocus Mobile 2 application Phocus Mobile 2 has allowed Hasselblad mirrorless photographers to remotely control, process and share their images on iPad for over a year. With the latest update to Phocus Mobile 2, photographers can now perform many of these same functions on an iPhone. Inspired by photographers like Dorothea Lange and Francesca Woodman, Roper wanted a safe way to capture portraits reflective of the challenging times we are living in.

Aug 13, 2020 31 Fotodiox's new adapter gives Leica Mmount lenses autofocus on Fujifilm X series cameras The new Pro Pronto AF adapter from Fotodiox brings AFS and AFC autofocus capabilities to Leica Mmount lenses used with Fujifilm X series cameras. Aug 13, 2020 62 Russell Kirsch, inventor of the pixel, dies in his Portland home at age 91 Kirsch is credited with being the inventor of the pixel, after capturing the first digital image in 1957. He passed away in his Portland, Oregon home August 11, 2020. Aug 13, 2020 77 Opinion Businesses, especially corporations, should pay to use your photos Have you ever been approached through social media, or even your own website, by a business or corporation asking for permission to use one of your photos. Aug 13, 2020 191 Open

source Raw processor Darktable gets substantial 3.2 update Open source software such as darktable is a free alternative to expensive standalone and subscriptionbased photo editing software. In its latest release, darktable version 3.2 includes many new features and performance improvements. Aug 12, 2020 37 These copperplated Leica cameras manage to make even broken rangefinders expensive Even when theyre broken and embalmed in copper, Leica cameras dont come cheap, apparently. Aug 12, 2020 148 camera news Tips or suggestions. And if you playback a movie on a card having a slow reading speed, the movie might not playback properly. To stop shooting the movie, press the button again. The suns heat can damage the cameras internal components. This is the exposure setting for taking a still photo. However, the sound will be properly recorded. This can degrade the image quality. While not shooting, turn off the power. You should turn off the power and allow the camera to rest for a while. Turn off the power and let the camera rest for a while. Tracking system Service Edge or Warranty Card and Customer Invoice date. Tracking system Service Edge or Warranty Card and Customer Invoice date.

<http://ninethreefox.com/?q=node/11219>